



Submersible Sewage Pumps
Cutter Impeller

C



The C-series incorporates a cutter mechanism consisting of a tungsten carbide tipped channel impeller and a saw-tooth suction cover surface hardened. The cutter mechanism cuts fibrous materials to small pieces permitting clog-free pumping.

Motor Protector

Each pump up to 7.5kW as standard has a built in auto-cut, self-resetting Circle Thermal Protector (CTP). Integrated in the motor housing, the CTP directly cuts the motor circuit if excessive heat builds up or an overcurrent caused by an electrical or mechanical failure occurs.

Miniature Thermal Protectors (MTPs) are imbedded in the winding of the pumps of star delta starting. These MTPs are connected in series, and their wires are led out of the motor. Should the winding temperature rise to the actuating temperature, the bimetal strip opens to cause the control panel to shut the power supply.

Cable Entry

Every cable has an anti-wicking block at the cable entry section of the pump. This mechanism is such that a part of each conductor is stripped back and the part is sealed by molded rubber or epoxy potting which has flowed in between each strand of the conductor. This unique feature prevents wicking under the strands of the conductor itself.

Mechanical Seal

All pumps are provided with a Silicon Carbide dual inside mechanical seal that is located completely out of the pumpage, running in an oil-filled chamber. The advantages of this seal are two-fold, it eliminates spring failure caused by corrosion, abrasion or fouling which prevents the seal faces from closing properly, and prevents loss of cooling to the bottom seal faces during run-dry conditions which causes the bottom seal to fail.

Motor

The motor is dry type, squirrel cage induction motor, housed in a cast iron, watertight casing, and conforms to insulation classes of E or F. In each of these insulation classes, all standard pumps can be used in ambient temperatures of 40 C.

Oil Lifter

Utilizing the rotational energy of the shaft seal, the Oil Lifter forcibly supply lubricating oil to the mechanical seal and continues to supply the oil to the top seal faces even if lubricant falls below the rated volume. This amazingly simple device not only turns wasted energy into added protection but also doubles the life expectancy of the mechanical seal and also the maintenance term.

Shaft

The high tensile stainless steel used on all pumps is designed to have an adequate strength for the transmission of the full load. Shafts are supported by C3 type, high quality, deep groove ball bearings.

Impeller & Suction Cover

A sintered tungsten carbide alloy tip is brazed onto the impeller vane, and it rotates on the serrated part of the suction cover. Incoming fibrous matters are cut up by this mechanism, and this prevents clogging in the pump discharge pipes or valves.

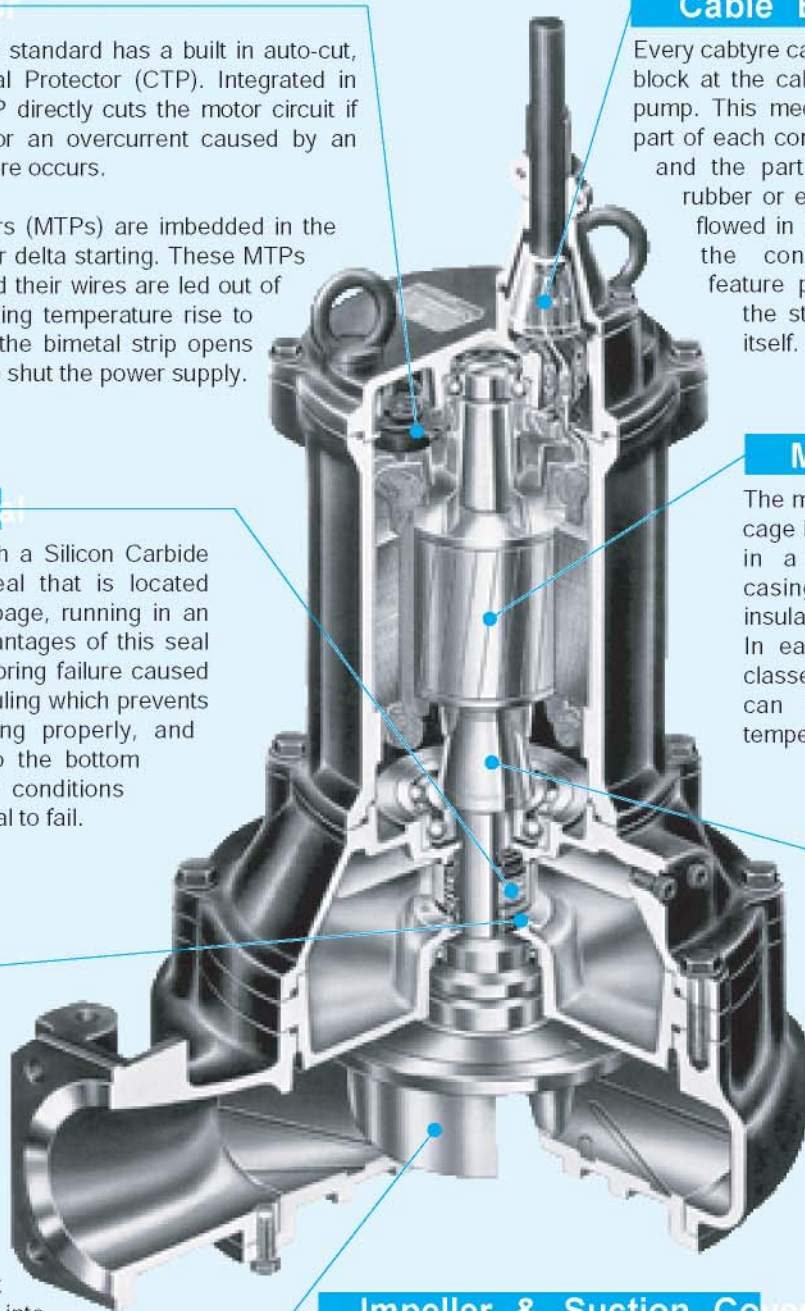

Discharge Bore

50 · 80 · 100mm

Performance Curves

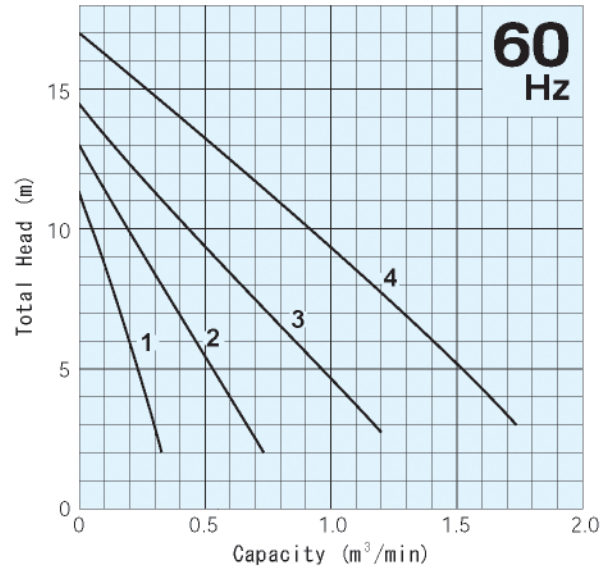
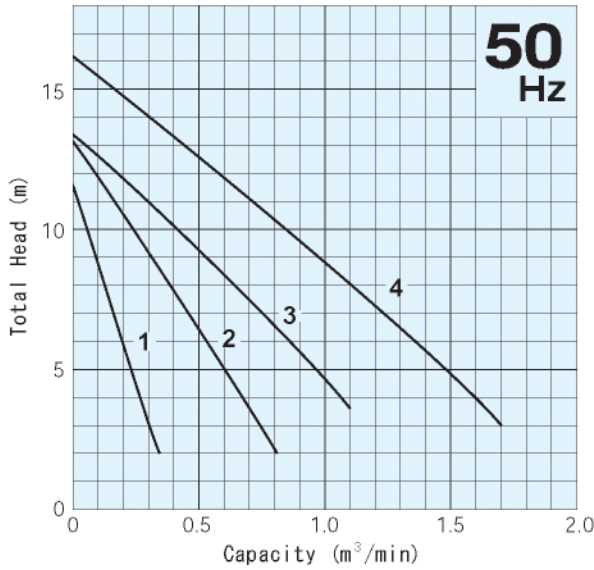

Specifications

Curve No.	Discharge Bore mm	Standard Model			Automatic Model			Auto-Alternation Model		
		Free Standing	Guide Rail Fitting		Free Standing	Guide Rail Fitting		Free Standing	Guide Rail Fitting	
			TOS	TS		TOS	TS		TOS	TS
1	50	50C2.75S	TOS50C2.75S	TS50C2.75S	50CA2.75S	TOS50CA2.75S	TS50CA2.75S	—	—	—
1	50	50C2.75	TOS50C2.75	TS50C2.75	50CA2.75	TOS50CA2.75	TS50CA2.75	50CW2.75	TOS50CW2.75	TS50CW2.75
2	80	80C21.5	TOS80C21.5	TS80C21.5	80CA21.5	TOS80CA21.5	TS80CA21.5	80CW21.5	TOS80CW21.5	TS80CW21.5
3	100	100C42.2	TOS100C42.2	TS100C42.2	—	—	—	—	—	—
4	100	100C43.7	TOS100C43.7	TS100C43.7	—	—	—	—	—	—
5	100	100C45.5	TOS100C45.5	TS100C45.5	—	—	—	—	—	—
6	100	100C47.5	TOS100C47.5	TS100C47.5	—	—	—	—	—	—
7	100	100C411	TOS100C411	TS100C411	—	—	—	—	—	—
8	100	100C415	TOS100C415	—	—	—	—	—	—	—

Cabtyre Cable

Single-Phase

Code	Pieces per Unit	Cores × mm ²	Dia. mm	Material
a	1	3 × 1.25	10.1	PVC Sheath

Three-Phase

Code	Pieces per Unit	Cores × mm ²	Dia. mm	Material
A	1	4 × 1.25	11.1	PVC Sheath
C	1	4 × 2	11.8	

The cables designated here are for 380 to 575 volts use. A thicker cable may be supplied on a certain 220 volts model.

Three-Phase

Code	Pieces per Unit	Cores × mm ²	Dia. mm	Material
H	1	4 × 3.5	14.1	Chloroprene Sheath
I	1	4 × 5.5	16.8	
L	3	4 × 3.5	14.1	
		3 × 3.5 2 × 2	12.9 10.6	
M	3	4 × 5.5	16.8	
		3 × 5.5 2 × 2	15.2 10.6	

Discharge Bore
100mm

■ Performance Curves

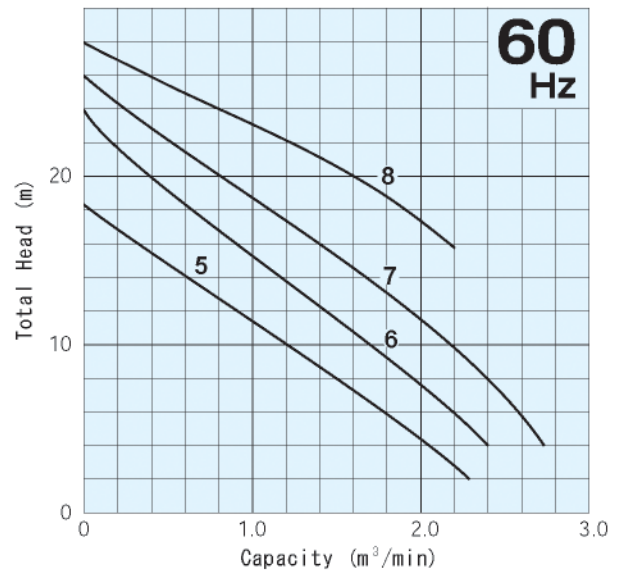
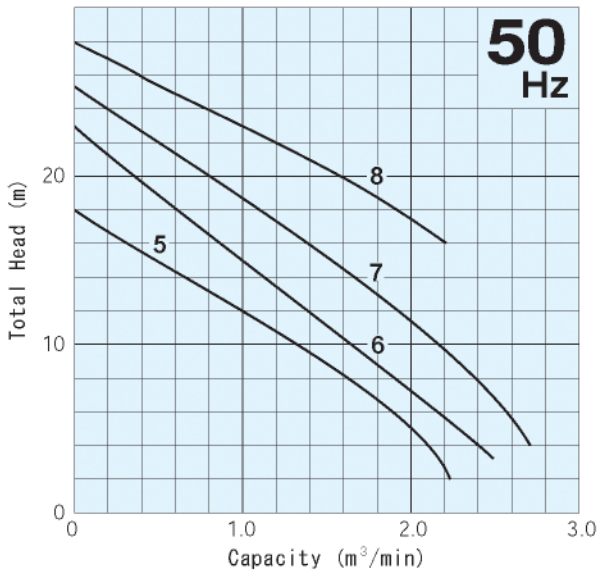

Motor Output kW	Phase	Speed (S.S.) 50Hz/60Hz min ⁻¹	Starting Method	Impeller Passage 50Hz/60Hz mm	Standard Cable Length m	Cable Code	Dimension L × H mm						Dry Weight kgs			
							Standard Model			Auto&Auto-Alternation Model			Standard Model		Auto&Auto-Alternation Model	
							Free Standing	Guide Rail Fitting		Free Standing	Guide Rail Fitting		Free Standing	Guide Rail Fitting ※	Free Standing	Guide Rail Fitting ※
								TOS	TS		TOS	TS				
0.75	Single	3000/3600	Capacitor	31×27/ 28×27	5	a	405×523	621×567	398×566	405×581	621×625	398×623	32	30	34	32
0.75	Three	3000/3600	D.O.L	31×27/ 28×27	6	A	405×412	621×456	398×456	405×500	621×544	399×538	24	23	25	24
1.5	Three	3000/3600	D.O.L	43×60/ 37×60	6	A	446×536	663×586	515×586	457×630	674×680	526×680	36	36	40	39
2.2	Three	1500/1800	D.O.L	67×56/ 62×56	6	C	596×616	754×631	599×631	—	—	—	68	64	—	—
3.7	Three	1500/1800	D.O.L	70×81/ 64×81	6	C	602×690	760×700	605×700	—	—	—	84	80	—	—
5.5	Three	1500/1800	D.O.L	82×68/ 68×68	8	H	687×908	905×906	709×906	—	—	—	142	135	—	—
7.5	Three	1500/1800	D.O.L	76×69/ 71×68	8	I	687×929	905×927	709×927	—	—	—	155	148	—	—
11	Three	1500/1800	Star-Delta	82×75/ 87×75	8	L	710×1000	928×998	733×998	—	—	—	178	171	—	—
15	Three	1500/1800	Star-Delta	87×45/ 77×40	8	M	707×1080	926×1078	—	—	—	—	322	315	—	—

※Weights without duckfoot bend.

■ Dimensions

Free Standing

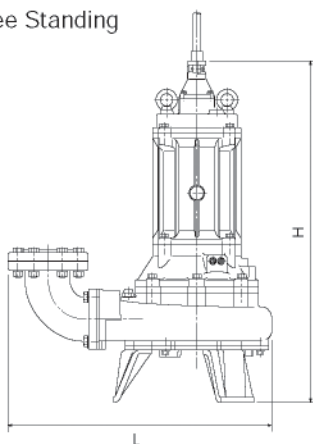

Guide Rail Fitting

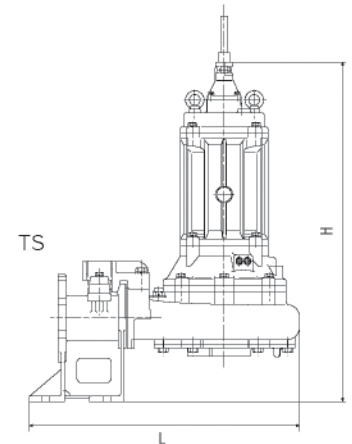
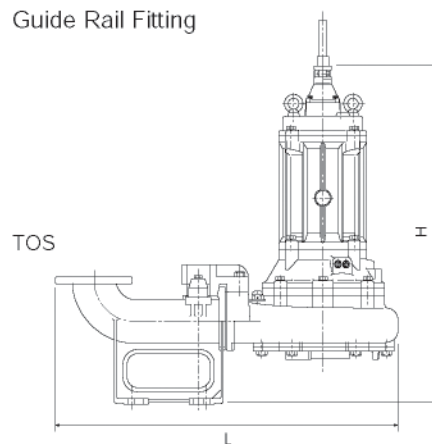

AUTO-ALTERNATION TYPE

In addition to standard automatic pumps, Tsurumi offers auto-alternation type pumps. Automatic alternation operation is achieved by combining a parent pump (three floats) with a standard automatic pump (two floats). This enables each pump to operate alternately without the aid of a control panel.

How the Auto-alternation Type Works

● Operation is enabled by merely connecting the power supply.

Primary Operation

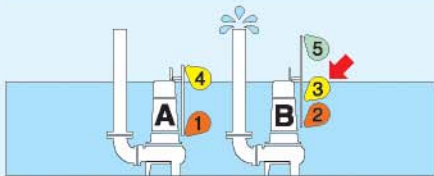

1 Float 3 operates, and pump B starts to discharge water.

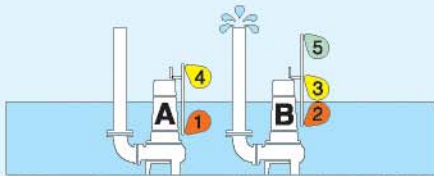

2 Water is discharged (water level falls).

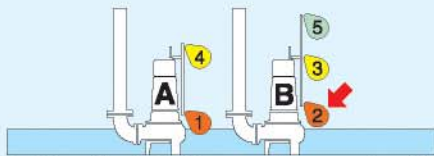

3 Stop float 2 of pump B operates to end water discharge. At this time, alternation start float 3 of pump B rests for one discharge operation.

Secondary Operation

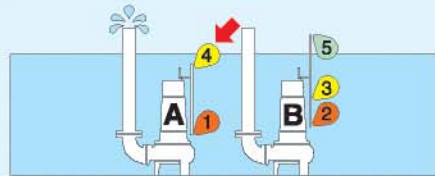

1 Start float 4 of pump A operates to start water discharge. The pump ends primary operation, and stops operating.

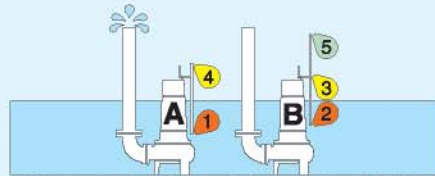

2 Water is discharged (water level falls).

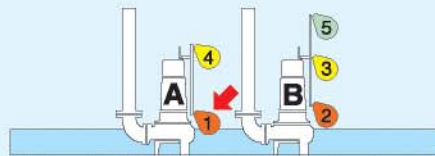

3 Stop float 1 of pump A operates to end water discharge. At the same time, start float 3 of pump B becomes ready for operation.

※ Primary operation and secondary operation are repeated alternately.

※ Both primary and secondary operations are performed simultaneously when water has risen to an abnormal level.

The parent pump can be identified by the identification "W". Auto-alternation type pumps are available in the same output range as standard automatic pumps.

COMPOSITION OF THE MODEL NAME

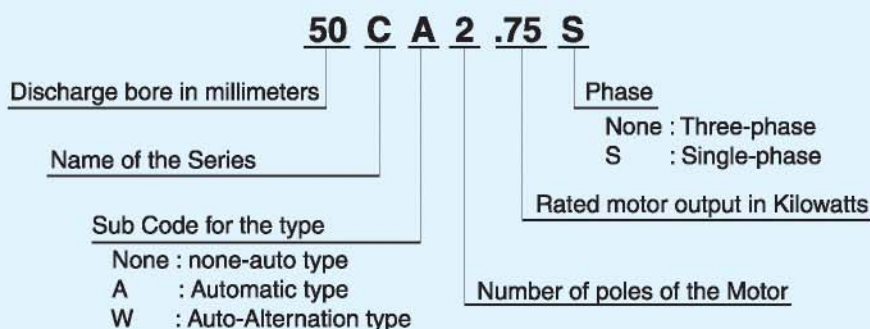

AUTOMATIC

The Tsurumi automatic type pump has an integral control circuit and two float switches operated at a low voltage. As the pump has a Circle Thermal Protector (CTP) integrated into the motor to protect the motor from overload or overheating, it is not required to provide an extra motor protection circuit in the starter panel.

This type can be identified by the suffix "A". Refer to the specification table for availability and model numbers.



GUIDE RAIL

TOS

We recommend using the Tsurumi "TOS" guide rail fitting system with pumps. This system connects the pump to and from the piping easily just by lowering and hoisting the pump, allowing easy maintenance and inspection without the need to enter the sump.



TS

This compact guide rail fitting system is ideal for installing on prefabricated lift stations. Its discharge flange is compatible with major flange standards including ANSI 150lb, BS PN10, and DIN PN10. Four models are available and can be used on Tsurumi cast-iron pumps in the 50 mm through 100 mm discharge bore range.



SPECIAL ACCESSORIES

■ FLOAT SWITCHES

Tsurumi offers two types of float switches (liquid level sensors). A micro-switch is incorporated in both types.

Model MC-2 is a heavy-duty type float switch with a shock absorber. Having equipped with a high grade micro switch, the MC-2 assures trouble-free operation in the liquid containing much suspended solids and floating scum. Either of the two contacts, normally-open or normally-close, can be selected as required.



Model RF-5 is an economy type float which can detect upper/lower-limit water levels with single float. The snap on-off action ensures stable operation in clean or waste water containing suspended solids or oil and fat.



TSURUMI OPTIONS

■ SPECIAL VERSION WITH GALVANIC CORRSION PROTECTION

In sea water, the effect of galvanic corrosion is more serious than that of ordinary corrosion. When two kinds of metals are dipped into an electrolytic liquid, a battery phenomenon occurs due to the difference in the electric potential of the two metals. In this case, the metal having the higher potential corrodes first. As an option, Tsurumi can supply pumps with parts made of higher electric potential metal as the sacrificial anode.

■ SPECIAL VERSION FOR HIGHER TEMPERATURE LIQUID

Standard pumps are designed for continuous running at the maximum ambient temperature of 40°C. In addition to these, Tsurumi can provide pumps for operation at higher liquid temperatures upon request. Refitting for operation at higher temperatures involves modification of not only the insulation of motor windings but also several components.

Two high-temperature operating models are available - the Rank 60 for operation in liquids up to 60°C and the Rank 90 for operation in liquids up to 90°C. Consult your dealer for more details. (These special versions are not available for some pump models.)

■ DRY PIT VERSION

The advantage of dry pit type pump is that it will not be damaged by a flooding of water, as it is constructed by a submersible pump. Tsurumi can provide dry pit type pumps as option for larger pumps in the C range pumps. Durable motor with effective water cooling jacket assures the pump continuous running without overheating.

■ SPECIAL VERSION WITH NON-STANDARD MATERIALS

Tsurumi can also provide you with pumps with essential components such as the impeller, pump casing, and the suction cover made of non-standard materials. Select from stainless-steel, chromium iron and bronze to suit your specific requirements. Consult your dealer for more details.

We reserve the right to change the specifications and designs for improvement without prior notice.